

These review questions are for Bio 1 Genetics topic. The questions were adapted from several sources, including the textbook's review questions.

1) What was the most significant conclusion that Gregor Mendel drew from his experiments with pea plants?

- A) There is considerable genetic variation in garden peas.
- B) Traits are inherited in discrete units, and are not blended in offspring.
- C) Recessive genes occur more frequently in the F₁ generation than do dominant ones.
- D) Genes are composed of DNA.
- E) An organism that is homozygous for many recessive traits is at a disadvantage.

2) In one of Mendel's experiments, a purple pea plant was crossed with a white pea plant. The F₁ generation (the offspring) were all purple. But when Mendel crossed the F₁ plants with each other the next generation (the F₂ generation) did have some white plants.

Mendel accounted for the observation that traits which had disappeared in the F₁ (such as the white trait) reappeared in the F₂ by proposing that...

- A) new mutations were frequently generated in the F₂ progeny, "reinventing" traits that had been lost in the F₁.
- B) the mechanism controlling the appearance of traits was different between the F₁ and the F₂ plants.
- C) traits can be dominant or recessive, and the recessive traits were covered up by the dominant ones in the F₁.
- D) the traits were lost in the F₁ due to dominance of the parental traits.
- E) members of the F₁ generation had only one allele for each trait, but members of the F₂ had two alleles for each trait.

3) In one of Mendel's experiments, a purple pea plant was crossed with a white pea plant. The F₁ generation (the offspring) were all purple. But when Mendel crossed the F₁ plants with each other the next generation (the F₂ generation) did have some white plants.

Why did the F₁ offspring of Mendel's classic pea cross always look like only one of the two parental varieties?

- A) No genes interacted to produce the parental phenotype.
- B) Each allele affected phenotypic expression.
- C) The traits blended together during fertilization.
- D) One allele was completely dominant over another.
- E) Different genes interacted to produce the parental phenotype.

4) In general, a dominant allele...

- A) Is close in DNA sequence to the recessive allele but not exactly the same

- B) Is the same in DNA sequence as the recessive allele
- C) Is not close in sequence to the recessive allele
- D) Encodes a non-functional protein whereas the recessive allele encodes a functional protein

5) In general, a dominant allele...

- A) Is the same in DNA sequence as the recessive allele
- B) Is not close in sequence to the recessive allele
- C) Encodes a functional protein whereas the recessive allele does not encode a functional protein
- D) Encodes a non-functional protein whereas the recessive allele encodes a functional protein

6) A sexually reproducing animal has two genes, one for head shape (H) and one for tail length (T). Its genotype is $HhTt$. Which of the following genotypes is possible in a gamete from this organism?

- A) tt
- B) Hh
- C) $HhTt$
- D) T
- E) HT

7) How many unique gametes could be produced through independent assortment by an individual with the genotype $AaBbCCDdEE$?

- A) 4
- B) 8
- C) 16
- D) 32
- E) 64

	D	d
D	1	2
d	3	4

8) In a particular plant, leaf color is controlled by gene locus D . Plants with at least one

allele D have dark green leaves, and plants with the homozygous recessive dd genotype have light green leaves. A homozygous dark-leaved plant is crossed with a light-leaved one, and the F_1 offspring is allowed to self-pollinate. The predicted outcome of the F_2 is diagrammed in the Punnett square shown in the figure above, where 1, 2, 3, and 4 represent the genotypes corresponding to each box within the square.

In the Punnett square above, which of the boxes marked 1-4 correspond to F_2 plants with dark leaves?

- A) 1 only
- B) 1 and 2
- C) 2 and 3
- D) 4 only
- E) 1, 2, and 3

9) In a particular plant, leaf color is controlled by gene locus D . Plants with at least one allele D have dark green leaves, and plants with the homozygous recessive dd genotype have light green leaves. A homozygous dark-leaved plant is crossed with a light-leaved one, and the F_1 offspring is allowed to self-pollinate. The predicted outcome of the F_2 is diagrammed in the previous Punnett square, where 1, 2, 3, and 4 represent the genotypes corresponding to each box within the square.

In the previous Punnett square, which of the boxes correspond to plants with a heterozygous genotype?

- A) 1
- B) 1 and 2
- C) 1, 2, and 3
- D) 2 and 3
- E) 2, 3, and 4

10) In a particular plant, leaf color is controlled by gene locus D . Plants with at least one allele D have dark green leaves, and plants with the homozygous recessive dd genotype have light green leaves. A homozygous dark-leaved plant is crossed with a light-leaved one, and the F_1 offspring is allowed to self-pollinate. The predicted outcome of the F_2 is diagrammed in the previous Punnett square, where 1, 2, 3, and 4 represent the genotypes corresponding to each box within the square.

In the previous Punnett square, which of the plants will be homozygous?

- A) 1 and 4 only
- B) 2 and 3 only
- C) 1, 2, 3, and 4
- D) 1 only
- E) 1 and 2 only

11) What do we mean when we use the terms *monohybrid cross* and *diybrid cross*?

- A) A monohybrid cross involves a single parent, whereas a diybrid cross involves two parents.
- B) A monohybrid cross produces a single offspring, whereas a diybrid cross produces two offspring.
- C) A diybrid cross involves crossing two genes and a monohybrid cross involves only one.
- D) A monohybrid cross is performed for one generation, whereas a diybrid cross is performed for two generations.
- E) A monohybrid cross results in a 9:3:3:1 ratio whereas a diybrid cross gives a 3:1 ratio.

12) Two plants are crossed, resulting in offspring with a 3:1 ratio for a particular trait. What does this suggest?

- A) that one parent was homozygous dominant for the trait and the other parent was homozygous recessive for the trait
- B) that the trait shows incomplete dominance
- C) that a blending of traits has occurred
- D) that the parents were both heterozygous for the trait
- E) that each offspring has the same alleles for each of two traits

13) The F_1 generation of the monohybrid cross purple (PP) x white (pp) flower pea plants should...

- A) All have white flowers
- B) All have light purple flowers (blended appearance)
- C) All have purple flowers
- D) Have 3/4 purple flowers and 1/4 white flowers
- E) Have 3/4 white flowers and 1/4 blue flowers

14) The F_1 generation of pea plants comes from a cross of purple (PP) x white (pp) plants. The F_1 plants are allowed to self cross. The phenotype ratio of the F_2 generation should be...

- A) All purple
- B) 1 purple: 1 white
- C) 3 purple: 1 white
- D) 3 white: 1 purple
- E) All white

15) Black fur in mice (B) is dominant to brown fur (b). Long tails (T) are dominant to short tails (t). What fraction of the offspring of crosses $BbTt$ x $BBtt$ will be expected to have black fur and long tails?

- A) 1/16
- B) 3/16
- C) 3/8
- D) 1/2
- E) 9/16

16) Two homozygous stocks of pea plants are crossed. One parent has red, short flowers and the other has white, long flowers. All F₁ individuals have red, short flowers. The F₁ flowers are crossed with each other to make the F₂ generation. What portion of the F₂ offspring would you expect to have red, long flowers?

- A) 9/16
- B) 1/16
- C) 3/16
- D) 1/8
- E) 1/4

17) Two homozygous stocks of pea plants are crossed. One parent has red, short flowers and the other has white, long flowers. All F₁ individuals have red, short flowers. The F₁ flowers are crossed with each other to make the F₂ generation. What portion of the F₂ offspring would you expect to have white short flowers?

- A) 9/16
- B) 1/16
- C) 3/16
- D) 1/8
- E) 1/4

18) *Drosophila* (fruit flies) usually have straight wings but a recessive allele in a certain gene can result in bent wings. Fruit flies usually have long wings but a recessive allele in another gene can result in short wings. If flies that are heterozygous for both the bent wing gene and the short wing gene are mated, what is the probability of offspring with long bent wings?

- A) 1/8
- B) 3/8
- C) 1/4
- D) 9/16
- E) 3/16

19) Gene *S* controls the sharpness of spines in a type of cactus. Cactuses with the dominant allele, *S*, have sharp spines, whereas homozygous recessive *ss* cactuses have dull spines. At the same time, a second gene, *N*, determines whether or not cactuses have spines. Homozygous recessive *nn* cactuses have no spines at all.

A sharp-spined cactus that is homozygous for the sharp-spined gene is crossed with a spineless cactus would produce...

- A) all sharp-spined offspring.
- B) 50% sharp-spined, 50% dull-spined offspring.
- C) 25% sharp-spined, 50% dull-spined, 25% spineless offspring.
- D) all spineless offspring.
- E) There is not enough information to determine the phenotypes of the offspring.

20) In a certain plant species, a gene controls whether the leaves are long or short. A different gene controls whether the leaves are smooth or hairy. One plant of this species has long smooth leaves. This plant is heterozygous for all of its genes. A different plant of this species has short hairy leaves. This plant is homozygous for all of its genes. A cross of the two plants produces offspring with all long smooth leaves in the F_1 generation. If this F_1 generation is allowed to self cross to produce the F_2 generation, what would you predict for the ratio of the F_2 phenotypes?

- A) 9 smooth long: 3 long hairy; 3 short hairy: 1 short smooth
- B) 9 smooth long: 3 long hairy; 3 short smooth: 1 short hairy
- C) 9 short hairy: 3 long hairy; 3 short smooth: 1 long hairy
- D) 1 smooth long: 1 long hairy; 1 short smooth: 1 short hairy

21) In the cross $AaBbCc \times AaBbCc$, what is the probability of producing an offspring with genotype $AABBCC$?

- A) 1/4
- B) 1/8
- C) 1/16
- D) 1/32
- E) 1/64

22) In the cross $AABBCC \times AabbCc$, assume simple dominance for each trait. What proportion of the offspring will be expected to have the same phenotype as the first parent?

- A) 1/4
- B) 1/8
- C) 3/4
- D) 3/8
- E) 1

23) In humans, brown eye color is _____ to blue eye color.

- A) Dominant
- B) Recessive
- C) Co-dominant
- D) Incompletely dominant

E) Sex linked

24) In humans, unattached earlobes are _____ to attached earlobes.

- A) Dominant
- B) Recessive
- C) Co-dominant
- D) Incompletely dominant
- E) Sex linked

25) In humans, brown eye color is dominant to blue eye color and unattached earlobes are dominant to attached earlobes. If a person with blue eyes and attached earlobes has children with a person with brown eyes and attached earlobes. Which statement about their children is true?

- A) Their children may have blue eyes and unattached earlobes
- B) Their children must have brown eyes but may have attached or unattached earlobes
- C) Their children must have brown eyes and attached earlobes
- D) Their children may have blue eyes and attached earlobes.
- E) Their children may have blue earlobes and unattached eyes.

26) Phenylketonuria (PKU) is a recessive human disorder in which an individual cannot convert amino acid A into amino acid B. If too much amino acid A accumulates in the person's body mental retardation can result. What is the treatment given to infants that have PKU?

- A) Feed them amino acid A in large amounts.
- B) Transfuse the patients with blood from unaffected donors.
- C) Regulate the diet of the affected persons to severely limit the uptake of amino acid A.
- D) Feed the patients the missing enzymes that convert amino acid A into amino acid B in a regular cycle, such as twice per week.
- E) Feed the patients an excess of amino acid B.

27) A human disease called neurofibromatosis (NF) is caused by a dominant gene. It may range from mildly to very severely expressed, but when it is expressed, it is expressed in all cells of the body. If a young child has the disease but neither of her parents do, which of the following is the best explanation?

- A) One parent or both parents are carriers the gene.
- B) The gene mutated in the gonads of one of the parents.
- C) The condition skipped a generation in the family.
- D) The gene mutated in the child after the child was born.

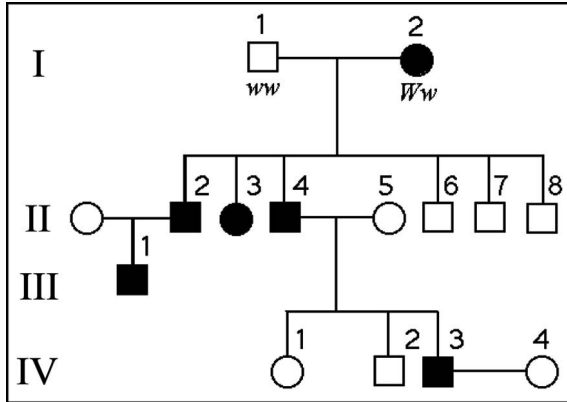

28) The pedigree chart shown above is for a family, some of whose members exhibit a trait caused by the dominant allele W . Individuals who exhibit the trait are indicated by a black square or black circle.

What is the genotype of individual II-5?

- A) WW
- B) Ww
- C) ww
- D) WW or ww
- E) ww or Ww

29) The previous pedigree chart is for a family, some of whose members exhibit a trait caused by the dominant allele W . Individuals who exhibit the trait are indicated by a black square or black circle.

What is the likelihood that the offspring of IV-3 and IV-4 will have the trait?

- A) 0%
- B) 25%
- C) 50%
- D) 75%
- E) 100%

30) The previous pedigree chart is for a family, some of whose members exhibit a trait caused by the dominant allele W . Individuals who exhibit the trait are indicated by a black square or black circle.

What is the probability that individual III-1 is Ww ?

- A) $3/4$
- B) $1/4$
- C) $2/4$
- D) $2/3$
- E) 1

31) Hutchinson-Gilford progeria is an exceedingly rare human genetic disorder in which there is very early senility and death, usually from coronary artery disease, at an average age of approximately 13. Patients do not live to reproduce. Which of the following is true?

- A) The allele might be dominant or recessive. There is not enough information to tell.
- B) One parent must be heterozygous and one must be homozygous for the allele.
- C) The mutant allele must be recessive.
- D) Each patient must have had at least one affected family member in a previous generation.

32) Hutchinson-Gilford progeria is an exceedingly rare human genetic disorder in which there is very early senility and death, usually from coronary artery disease, at an average age of approximately 13. Patients do not live to reproduce. Which of the following is true?

- A) The allele might be dominant or recessive. There is not enough information to tell.
- B) One parent must be heterozygous and one must be homozygous for the allele.
- C) Both parents of the patient must be carriers of the disease.
- D) Each patient must have had at least one affected family member in a previous generation.

33) If an organism is diploid and a certain gene found in the organism has 18 known alleles (variants), then any given organism of that species can/must have which of the following?

- A) at most, 2 alleles for that gene
- B) up to 18 chromosomes with that gene
- C) up to 18 genes for that trait
- D) a haploid number of 9 chromosomes
- E) up to, but not more than, 18 different traits

34) In cattle, roan coat color (mixed red and white hairs) occurs in the heterozygous (Rr) offspring of red (RR) and white (rr) homozygotes. Which of the following crosses would produce offspring in the ratio of 1 red:2 roan:1 white?

- A) red x white
- B) roan x roan
- C) white x roan
- D) red x roan
- E) The answer cannot be determined from the information provided.

35) A woman who has blood type A has a daughter who is type O and a son who is type B. Which of the following is the genotype for the son?

- A) $I^B I^B$
- B) $I^A I^B$
- C) ii
- D) $I^A I^A$
- E) $I^B i$

36) A woman who has blood type A has a daughter who is type O and a son who is type B. Which of the following is the genotype for the mother?

- A) $I^B i$
- B) $I^A I^B$
- C) ii
- D) $I^A I^A$
- E) $I^A i$

37) A woman who has blood type A has a daughter who is type O and a son who is type B. Which of the following is the genotype for the father?

- A) $I^B i$
- B) $I^A I^B$
- C) ii
- D) $I^A I^A$
- E) $I^A i$

38) A woman who has blood type A has a daughter who is type O and a son who is type B. Which of the following is the phenotype (the blood type) of the father?

- A) A
- B) O
- C) B
- D) AB

39) Tallness (T) in snapdragons is dominant to dwarfness (t), while red (R) flower color is incompletely dominant to white (r): The heterozygous condition for the color gene results in pink (Rr) flower color.

A dwarf, red snapdragon is crossed with a plant homozygous for tallness and white flowers. What are the genotype and phenotype of the F_1 individuals?

- A) $ttRr$ —dwarf and pink
- B) $ttrr$ —dwarf and white
- C) $TtRr$ —tall and red
- D) $TtRr$ —tall and pink
- E) $TTRR$ —tall and red

40) In snapdragons red (R) flower color is incompletely dominant to white (r): The heterozygous condition for the color gene results in pink (Rr) flower color.

If two snapdragons are heterozygous for flower color, a mating between them will result in what phenotype ratio?

- A) 9:3:3:1
- B) 6:3:3:2:1:1
- C) 1:2:1
- D) 27:9:9:9:3:3:3:1
- E) 9:4:3

41) You discover a new variety of plant. Some have purple flowers and some have white flowers. When you cross these plants, the F_1 is light purple. You consider that this may be an example of incomplete dominance. If it is incomplete dominance, what would you predict for the F_2 if two light purple plants are crossed?

- A) 1 purple: 2 white: 1 light purple
- B) 1 white: 2 purple: 1 light purple
- C) 1 purple: 2 light purple: 1 white
- D) 1 light purple: 2 purple: 1 white

42) Radish flowers may be red, purple, or white. A cross between a red-flowered plant and a white-flowered plant yields all-purple offspring (The purple color is the results of a smaller amount of the same red pigment found in red radishes). The part of the radish we eat may be oval or long, with long being the dominant characteristic.

If homozygous red long radishes are crossed with homozygous white oval radishes, the F_1 will be expected to be which of the following?

- A) red and long
- B) red and oval
- C) white and long
- D) purple and long
- E) purple and oval

43) Phenotypes that show a very wide variety of phenotypes, such as skin color, are usually the result of...

- A) An alteration of dominance for multiple alleles of a single gene
- B) The presence of multiple alleles for a single gene
- C) The action of one gene on multiple phenotypes
- D) The action of multiple genes on a single phenotype
- E) Codominance

44) Skin color in humans results from 3 different genes contributing to the total amount

of melanin pigment in the skin. Each gene's dominant allele encodes a protein that makes melanin. Each gene's recessive allele encodes a protein that does not make any melanin. In each gene, the dominant allele is incompletely dominant.

Fred's genotype for these three genes is AABbcc. Which genotype below is the genotype of a person that has the same skin color as Fred?

- A) AaBbCc
- B) AABbCc
- C) aabbCC
- D) AABbCc
- E) aaBbCc

45) The human X and Y chromosomes...

- A) are both present in every somatic cell of males and females alike.
- B) are of approximately equal size and number of genes.
- C) are almost entirely homologous, despite their different names.
- D) include genes that determine an individual's sex.
- E) include only genes that govern sex determination.

46) A human cell containing 22 autosomes and a Y chromosome is...

- A) a sperm.
- B) an egg.
- C) a zygote.
- D) a non-gamete cell in the body of a male.
- E) a non-gamete cell in the body of a female.

47) Genes on the X and Y chromosomes are called...

- A) Autosomal genes
- B) Linked genes
- C) Non-Mendelian genes
- D) Mendelian genes
- E) Sex linked genes

48) Males are more often affected by sex-linked traits than females because...

- A) male hormones such as testosterone often alter the effects of mutations on the X chromosome.
- B) female hormones such as estrogen often compensate for the effects of mutations on the X chromosome.
- C) X chromosomes in males generally have more mutations than X chromosomes in females.
- D) males are haploid for genes on the X chromosome.
- E) mutations on the Y chromosome often worsen the effects of X-linked mutations.

49) Red-green color blindness is a sex-linked recessive trait in humans. Two people with normal color vision have a color-blind son. What are the genotypes of the parents? (Q = allele for normal color vision, q = allele for color blindness)

- A) $Xq Xq$ and $Xq Y$
- B) $XQ XQ$ and $Xq Y$
- C) $XQ Xq$ and $Xq Y$
- D) $Xq Xq$ and $XQ Y$
- E) $XQ Xq$ and $XQ Y$

50) Cinnabar eyes is a sex-linked recessive characteristic in fruit flies. If a female having cinnabar eyes is crossed with a normal (red eye) male, what percentage of the F₁ males will have cinnabar eyes?

- A) 0%
- B) 25%
- C) 50%
- D) 75%
- E) 100%

51) Duchenne muscular dystrophy (DMD) is caused by a recessive gene on the human X chromosome. The patients have muscles that weaken over time because they have absent or decreased dystrophin, a muscle protein. They rarely live past their 20s. In what circumstances could a woman have this condition?

- A) Women can never have this condition.
- B) One-half of the daughters of an unaffected man and a carrier mother could have this condition.
- C) One-half of the daughters of an affected father and a carrier mother could have this condition.
- D) A woman could only get this condition if her own dystrophin gene mutated.
- E) Only if a woman is XXX could she have this condition.

52) Achondroplastic dwarfism is autosomal dominant, and red-green color blindness is X-linked recessive. A man who is an achondroplastic dwarf with normal vision marries a color-blind woman of normal height. The man's father was 6 feet tall, and both the woman's parents were of average height. Use this information to answer the question below.

What portion of their daughters might be expected to be color-blind dwarfs?

- A) all
- B) none
- C) half
- D) one out of four

E) three out of four

53) Achondroplastic dwarfism is autosomal dominant, and red-green color blindness is X-linked recessive. A man who is an achondroplastic dwarf with normal vision marries a color-blind woman of normal height. The man's father was 6 feet tall, and both the woman's parents were of average height. Use this information to answer the question below.

What proportion of their sons would be color-blind and of normal height?

- A) none
- B) half
- C) one out of four
- D) three out of four
- E) all

54) Achondroplastic dwarfism is autosomal dominant, and red-green color blindness is X-linked recessive. A man who is an achondroplastic dwarf with normal vision marries a color-blind woman of normal height. The man's father was 6 feet tall, and both the woman's parents were of average height. Use this information to answer the question below.

They have a daughter who is a dwarf with normal color vision. What is the probability that she is heterozygous for both genes?

- A) 0%
- B) 25%
- C) 50%
- D) 75%
- E) 100%

55) Unlike males, a woman who is a carrier of a recessive gene (heterozygous for the gene) may show the recessive phenotype in certain parts of her body and the dominant phenotype in other parts of her body. This is called being a "manifesting carrier" For example, a woman carrying the muscular dystrophy gene may experience muscle weakness in some muscles but not others. Being a manifesting carrier is caused by...

- A) inactivation of one X chromosome in each cell when she was an embryo
- B) the gene being located on the Y chromosome
- C) crossover between one X chromosome and a related gene on an autosome
- D) inheriting the recessive allele on an autosome from her male parent
- E) inheriting the recessive allele on an autosome from her female parent

56) In cats, black fur color is caused by an X-linked allele; the other allele at this locus causes orange color. The heterozygote is tortoiseshell. What kinds of offspring would you

expect from the cross of a black female and an orange male?

- A) tortoiseshell females; tortoiseshell males
- B) black females; orange males
- C) orange females; orange males
- D) tortoiseshell females; black males
- E) orange females; black males

57) Autosomes are...

- A) The chromosomes that differ between the sexes
- B) Chromosomes that are involved in sex determination
- C) Only inherited from the mother (maternal inheritance)
- D) All the chromosomes other than sex chromosomes
- E) All the chromosomes that can self duplicate

58) Making a visual display of the chromosomes in a cell using a microscope is known as...

- A) Abortion
- B) Aneuploidy
- C) Amniocentesis
- D) Euploidy
- E) Karyotyping

59) The karyotype of one species of primate has 48 chromosomes. In a particular female, cell division goes awry and she produces one of her eggs with an extra chromosome (25 chromosomes in the egg) The most probable source of this error would be a mistake in which of the following?

- A) mitosis in her ovary
- B) metaphase of meiosis 1
- C) telophase of meiosis 2
- D) telophase I of meiosis 1
- E) anaphase of meiosis 1 or of meiosis 2

60) 4 sperm cells are made from a diploid mother cell in the testes by meiosis. If nondisjunction occurs to one cell during meiosis II when the sperm are being made, what will be the result at the completion of meiosis?

- A) All 4 of the sperm will be diploid.
- B) 2 of the sperms will be $n + 1$, and 2 will be $n - 1$.
- C) 1 of the sperms will be $n + 1$, 1 will be $n - 1$, and 2 will be n .
- D) There will be three extra sperms.
- E) Two of the four sperms will be haploid, and two will be diploid.

61) Which of the following might result in a human zygote with 45 chromosomes?
A) an error in either egg or sperm meiotic anaphase
B) failure of the egg nucleus to be fertilized by the sperm
C) fertilization of a 23 chromosome human egg by a 22 chromosome sperm of a closely related species
D) an error in the alignment of chromosomes on the metaphase plate
E) lack of crossing over in prophase I

62) A woman is found to have 45 chromosomes, because she has only one X chromosome. Which of the following describes her expected phenotype?
A) male sex organs and masculine characteristics such as facial hair
B) enlarged genital structures
C) mental retardation
D) normal female
E) sterile female

63) A woman is found to have 45 chromosomes, because she has only one X chromosome. What is the name of this chromosomal abnormality?
A) Jacob's syndrome
B) Turner's syndrome
C) Klinefelter's syndrome
D) X-chromosome inactivation
E) Down syndrome

64) What is the possible source of the extra chromosome 21 in an individual with Down syndrome?
A) nondisjunction in the mother only
B) nondisjunction in the father only
C) duplication of the chromosome
D) nondisjunction in either parent
E) hyperactivity in DNA polymerase III enzyme

65) What is the largest risk factor for a couple having a child with Down syndrome?
A) One member of the couple is a carrier of Down syndrome.
B) One member of the couple has Down syndrome.
C) The age of the female.
D) The age of the male.
E) The mother has a chromosomal duplication.

66) Of the following human aneuploidies, which is the one that generally has the most severe impact on the physical and mental abilities of the individual?

- A) 47 chromosomes due to three chromosome 21's
- B) 47 chromosomes, due to XXY for the sex chromosomes
- C) 47 chromosomes, due to XXX for the sex chromosomes
- D) 47 chromosomes, due to XYY for the sex chromosomes
- E) 45 chromosomes, due to one X only for the sex chromosomes

67) What is meant when we say that certain gene is in Hardy-Weinberg equilibrium?

- A) The allele's frequency does not change from one generation to the next.
- B) Evolution is acting to change an allele's frequency.
- C) The two alleles are present in equal proportions.
- D) The number of individuals that make up the population is steady.

68) In a population with two alleles, A and a , the frequency of the allele a is 0.3. What is the genotype frequency of aa genotype (homozygous recessive) in the population? The population is in Hardy-Weinberg equilibrium.

- A) 0.09
- B) 0.49
- C) 60.0
- D) 0.6
- E) 49.0

69) In a Hardy-Weinberg population with two alleles, A and a , that are in equilibrium, the frequency of allele a is 0.2. What is the percentage of the population that is heterozygous for this allele?

- A) 0.2
- B) 2.0
- C) 4.0
- D) 16.0
- E) 32.0

70) In a Hardy-Weinberg population with two alleles, A and a , that are in equilibrium, the frequency of allele a is 0.1. What is the frequency of individuals with AA genotype?

- A) 0.20
- B) 0.32
- C) 0.42
- D) 0.81
- E) Genotype frequency cannot be determined from the information provided.

71) If 49% of the members of a population are homozygous dominant for a particular gene, then what is the allele frequency of the dominant allele?

- A) 0.245

- B) 0.94
- C) 0.54.
- D) 0.70
- E) There is not enough information to say.

72) You sample a population of butterflies and find that 85% are homozygous recessive at a particular locus. What should be the frequency of the recessive allele in this population?

- A) 0.07
- B) 0.85
- C) 0.92
- D) 0.75
- E) Allele frequency cannot be determined from this information.

73) In peas, a gene controls flower color such that R = purple and r = white. In an isolated pea patch, there are 36 purple-flowering plants and 64 white-flowering plants. Assuming Hardy-Weinberg equilibrium, what is the value of the recessive allele frequency for this population?

- A) 0.36
- B) 0.64
- C) 0.75
- D) 0.80

74) A large population of laboratory animals has been allowed to breed randomly for a number of generations. After several generations, 25% of the animals display a recessive trait (aa), the same percentage as at the beginning of the breeding program. The rest of the animals show the dominant phenotype, with heterozygotes indistinguishable from the homozygous dominants.

What is the most reasonable conclusion that can be drawn from the fact that the frequency of the recessive trait (aa) has not changed over time?

- A) The recessive trait is advantageous enough to counteract its loss of expression in heterozygotes.
- B) The two phenotypes are about equally advantageous under laboratory conditions.
- C) The genotype AA is lethal.
- D) There has been a high rate of mutation of allele A to allele a .
- E) Mating favors the allele a but natural selection favors the A allele.

75) A large population of laboratory animals has been allowed to breed randomly for a number of generations. After several generations, 25% of the animals display a recessive trait (aa), the same percentage as at the beginning of the breeding program. The rest of the animals show the dominant phenotype, with heterozygotes indistinguishable from the homozygous dominants.

What is the estimated frequency of allele A in the gene pool?

- A) 0.25
- B) 0.50
- C) 0.75
- D) 0.0
- E) There is not enough information to estimate allele frequencies

76) A large population of laboratory animals has been allowed to breed randomly for a number of generations. After several generations, 25% of the animals display a recessive trait (aa), the same percentage as at the beginning of the breeding program. The rest of the animals show the dominant phenotype, with heterozygotes indistinguishable from the homozygous dominants.

What proportion of the population is probably heterozygous (Aa) for this trait?

- A) 0.05
- B) 0.25
- C) 0.50
- D) 0.75

77) In those parts of equatorial Africa where the malaria parasite is most common, the sickle-cell allele constitutes 20% of the hemoglobin alleles in the human gene pool. In other words, the allele frequency of the sickle-cell allele is 0.2.

Assuming Hardy-Weinberg equilibrium, what should be the proportion of heterozygous individuals in populations that live here?

- A) 0.04
- B) 0.16
- C) 0.20
- D) 0.32
- E) 0.80

78) In those parts of equatorial Africa where the malaria parasite is most common, the sickle-cell allele constitutes 20% of the hemoglobin alleles in the human gene pool. In other words, the allele frequency of the sickle-cell allele is 0.2.

Assuming Hardy-Weinberg equilibrium, if the sickle-cell allele is recessive, what proportion of the population should be susceptible to sickle-cell anemia (which results from being homozygous recessive) under typical conditions?

- A) 0.04
- B) 0.16
- C) 0.20
- D) 0.32

E) 0.80

79) In the year 2500, five male space colonists and five female space colonists (all unrelated to each other) settle on an uninhabited Earthlike planet in the Andromeda galaxy. The colonists and their offspring randomly mate for generations. All ten of the original colonists had unattached earlobes (caused by the dominant allele A for the gene that controls ear lobe shape), and two were heterozygous for that trait.

Which of these is closest to the allele frequency in the founding population?

A) 0.1 a , 0.9 A

B) 0.2 a , 0.8 A

C) 0.5 a , 0.5 A

D) 0.8 a , 0.2 A

E) 0.4 a , 0.6 A

80) In the year 2500, five male space colonists and five female space colonists (all unrelated to each other) settle on an uninhabited Earthlike planet in the Andromeda galaxy. The colonists and their offspring randomly mate for generations. All ten of the original colonists had unattached earlobes (caused by the dominant allele A for the gene that controls ear lobe shape), and two were heterozygous for that trait. This means that the allele frequency of $A = 0.9$.

If one assumes that Hardy-Weinberg equilibrium applies to the population of colonists on this planet, about how many people will have attached earlobes when the planet's population reaches 100,000?

A) 1000

B) 4000

C) 8000

D) 10,000

E) 100,000

81) A fruit fly population has a gene with two alleles, $A1$ and $A2$. Tests show that 70% of the gametes produced in the population contain the $A1$ allele. If the population is in Hardy-Weinberg equilibrium, what proportion of the flies carry both $A1$ and $A2$?

A) 0.7

B) 0.49

C) 0.21

D) 0.42

E) 0.09

82) During the process of spermatogenesis (making sperm by meiosis) a non-disjunction event that occurs during meiosis 1 makes...

- A) All four sperm aneuploid
- B) Two of the four sperm aneuploid
- C) None of the four sperm cells aneuploid

Answers to review questions:

- 1) B
- 2) C
- 3) D
- 4) A
- 5) C
- 6) E
- 7) B
- 8) E
- 9) D
- 10) A
- 11) C
- 12) D
- 13) C
- 14) C
- 15) D
- 16) C
- 17) C
- 18) E
- 19) E
- 20) B
- 21) E
- 22) C
- 23) A
- 24) A
- 25) D
- 26) C
- 27) B
- 28) C
- 29) C
- 30) E
- 31) C
- 32) C
- 33) A
- 34) B
- 35) E
- 36) E

- 37) A
- 38) C
- 39) D
- 40) C
- 41) C
- 42) D
- 43) D
- 44) A
- 45) D
- 46) A
- 47) E
- 48) D
- 49) E
- 50) E
- 51) C
- 52) B
- 53) B
- 54) E
- 55) A
- 56) D
- 57) D
- 58) E
- 59) E
- 60) C
- 61) A
- 62) E
- 63) B
- 64) D
- 65) C
- 66) A
- 67) A
- 68) A
- 69) E
- 70) D
- 71) D
- 72) C
- 73) D
- 74) B
- 75) B
- 76) C
- 77) D
- 78) A
- 79) A
- 80) A
- 81) D
- 82) A

